

Cabinet Lock 21 10

Standalone pushbutton lock



Advantages at a glance

- Efficient security: with the electronic cabinet lock, there is no need for the labourious administration of keys
- Seamless integration into the dormakaba system environment with digital cylinders, electronic fittings and readers
- Convenience – just hold the access card to the door to open the locker
- Discreet and elegant: the cabinet lock is installed inside the locker and is battery operated with no wiring
- Sturdy construction and an alarm provide high security
- High level of functionality: meets virtually every requirement of a cabinet lock

Electronic access security

With the electronic cabinet lock, you can protect your personal documents and materials against unauthorised access in wardrobes, lockers and other furniture – easily and conveniently without turning a key. You briefly hold your access card, key or RFID key fob to the cabinet door to unlock it. To close the door again, simply push it and the door locks itself.

Can be integrated into existing systems

The cabinet lock can be seamlessly integrated into both our standalone and online access systems. This enables you to access rooms and open cabinets with just one access medium. Time-consuming administration of keys is thus a thing of the past. Likewise, you no longer need to worry about forgotten PIN codes or the costly replacement of keys and locks in the event of loss.

Fast installation

Whether you install it horizontally or vertically, the lock fits almost any cabinet thanks to its slim design. You can design the front of the furniture according to your requirements, as the lock is installed inside the locker. The RFID-based lock can be mounted on virtually any material, including wood, plastic, metal and glass.

Areas of application

From offices and schools to the healthcare sector, the cabinet lock is suitable for use in many different settings. Typical applications are:

- Lockers or material storage cabinets
- Safety deposit and post boxes
- Office furniture and drawers
- Medicine cabinets and patient lockers

Features

Robust and secure

The sturdy housing features a strong steel bolt and thus offers a high level of resistance against break-ins. In addition to a dead bolt monitoring device, a separate alarm contact detects unauthorised opening attempts. The contents of your cabinet are therefore as secure as possible.

Innovative energy management

The lock is battery operated and works without complicated wiring. The battery lasts for up to five years and a warning is displayed when it is about to run out. But don't worry: even if the battery is completely dead, the built-in energy storage device ensures that the door can still be opened.

Intelligent access management

Unlike a complex key management system, this solution allows you to obtain an overview of who currently has which access options. These rights can also be reprogrammed quickly and adapted to new situations.

Another useful feature is the "free choice of locker": your visitors or employees can be allocated any free locker. The lock memorises the access card, allowing optimal use to be made of a limited number of available lockers.

Efficient programming

Choose from the following programming options:

- Authorisation in the component:
 - with the programming card
 - with the smartphone app (evolo smart*)
 - with the system software and transfer of access rights via programming device
- Authorisations on the access medium – programming of the component on site is not necessary. Optionally available with:
 - CardLink or AoC (Access on Card)
 - OSS-SO (Open Security Standards – Standard Offline)
 - Mobile Access: access with your smartphone via Near Field Communication (NFC)

* with Android Smartphones

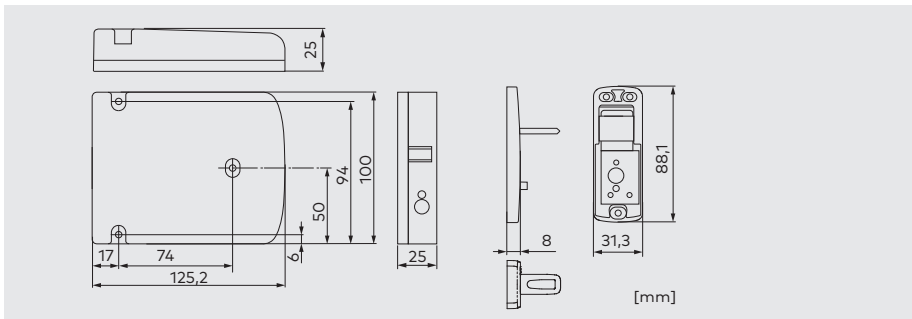

cabinet lock 21 10: side lock with door latch for non-metal doors

Technical data

Supported RFID standards

- LEGIC (advant & prime)
- MIFARE (DESFire & Classic)
- OSS-SO version 2021-06 (LEGIC advant, MIFARE DESFire)
- NFC - Near Field Communication (with Android Smartphones)

Versions

- Door latch for non-metal, metal and glass doors
- Plastic (PC) housing

Functions

- Free choice of locker
- Closure with or without ID
- Alarm in the event of attempted break-in
- Internal real-time clock
- Number of access media:
 - whitelist up to 4,000
 - CardLink virtually unlimited
- Audit trail of last 2,000 lock transactions

Dimensions

- Side lock (L x W x H): 125 x 100 x 25 mm
- Door latch for non-metal doors (L x W x H): 31 x 88 x 8 mm
- Door thickness: up to 22 mm

Power supply

- Lithium battery 1 x 3.6 V, AA

Environment/service life

- Temperature: 0 °C to +50 °C
- Class of protection: IP52
- Humidity: 0 to 90% rH, non-condensing
- Battery service life at 20 °C: up to 50,000 cycles or up to 5 years

Break-in resistance

- Fulfills requirement for lockers according to DIN 4547-2, grade C

Any questions? We would be happy to advise you.

dormakaba Australia | info.au@dormakaba.com | T 1800 675 411 | www.dormakaba.com.au

dormakaba New Zealand | info.nz@dormakaba.com | T 0800 436 762 | www.dormakaba.co.nz